

BRAC

Stainless steel
Acero inoxidable









REF. A10002



Our most robust model
with a sleek design
El diseño más robusto
y elegante



Automatic self-
adjusting brake
Freno automático
auto-ajustable

-  **Dimensions: 1030 x 670 x H1040 mm**
 Dimensiones: 1030 x 670 x H1040 mm
Nesting distance: 270 mm
 (10 trolleys: 3460 mm)
 Distancia de encajamiento: 270 mm
 (10 carros: 3460 mm)
-  **Trolley advertising space: 568 x 430 mm**
 Medidas panel publicitario: 568 x 430 mm
-  **Wheels: 1 swivel and 2 fixed. Ø 180 mm**
 PA, Natural Rubber
 Ruedas: 1 pivotante y 2 fijas. Ø 180 mm
 PA, Goma natural
-  **Weight: 20 kg**
 Peso: 20 kg
-  **Nominal load capacity: 250 kg**
 Capacidad de carga nominal: 250 kg
-  **Material: Stainless steel with electrochemical polishing**
 Material: Acero inoxidable de pulido electroquímico
-  **Electrochemical polished finish**
 Acabado pulido electroquímico
Basket frame: Steel Q235, Chrome plated, stainless steel
 Estructura de la cesta: Acero Q235, cromado, acero inoxidable.
-  **Ventral angle: 12°**
 Ángulo ventral: 12°

	REF.	Contenedor 20 pies 20 ft container	Contenedor 40 pies 40 ft container
Brac	A10002	108	264
			*Bajo pedido/ On request

BRAC

Dibujo técnico
Technical design

REF. A10002

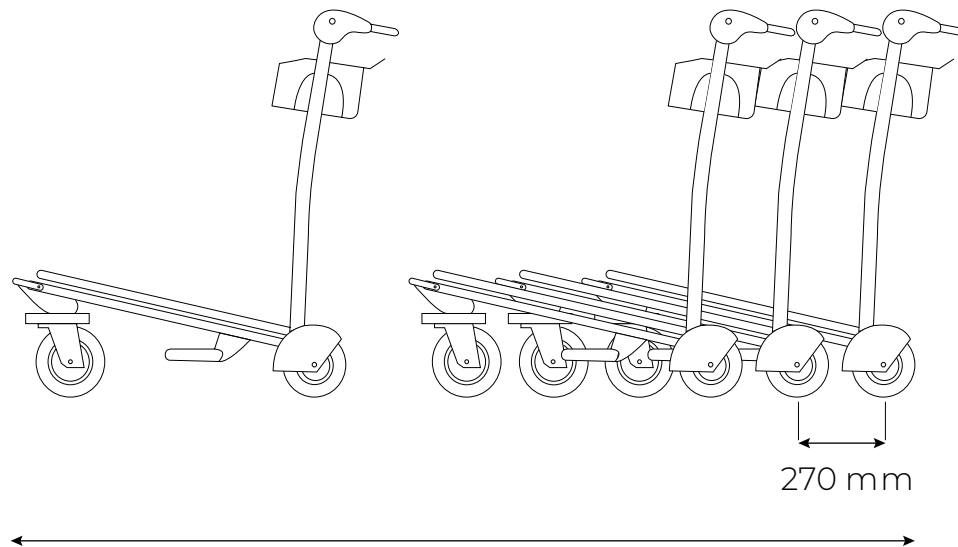
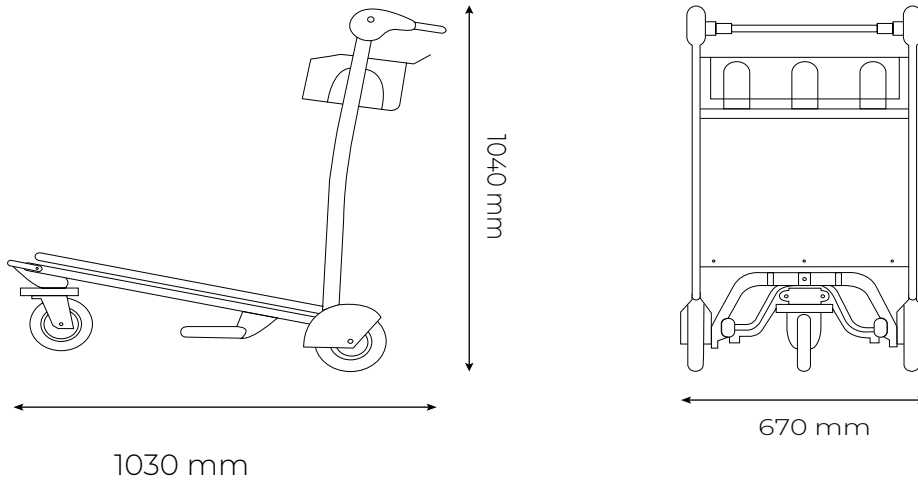

10 trolleys / carros = $270 \times 9 + 1030 = 3460$ mm